

Xtreme™

BuildingProducts

When doing it right matters!

TAMLYN
FAMILY. VALUE. SERVICE.
UNITED KINGDOM

XTREME BUILDING PRODUCTS

UK & Europe March 2024 product catalogue

50
1971-2021
TAMLYN

MADE PRODUCTS | KUMHAR TRIM | BIRING VENTS | REDELOS | RENOS | VARIOUS | REINFORCEMENT

Internal Corner External Corner End Profile Flash Profile Vertical Profile

Superior Packaging

We go to great lengths to ensure our products arrive in saleable condition

TAMLYN
UNITED KINGDOM



Tamlyn UK , winners of the Global innovations award for their Xtreme aluminium cladding system.

IBS show, Las Vegas 2024



INTRODUCING

Xtreme Top Hats

- Class A fire rated
- Timber batten alternative
- Stainless steel, galv or aluminium
- Made in the UK
- Pre-drilled fixing points
- Vented and unvented options
- Various sizes available
- Bespoke requirements welcome
- Popular sizes in stock now

TAMLYN
UNITED KINGDOM
Family - Value - Service
Providing Quality Building Products Since 1971
www.tamlyn.uk

INTRODUCING

Xtreme Vent Trim

- Made in the UK
- 4 top vents and 2 starter vents
- Superior packaging
- Reversible options (25mm/50mm)
- 15 year limited warranty
- To suit 25mm, 38mm, 50mm batten
- In stock now
- Next Day Delivery!

TAMLYN
UNITED KINGDOM
Family - Value - Service
Providing Quality Building Products Since 1971
www.tamlyn.uk

Internal Corner External Corner End Profile Flash Profile Vertical Profile

Powder Coated Trims

TAMLYN
UNITED KINGDOM

Why do we powder coat our trims?

- ▶ It provides a hardwearing finish ✓
- ▶ It allows for trim edges to be coated ✓
- ▶ Coated edges = less risk of injury ✓

TAMLYN®

FAMILY. VALUE. SERVICE.
UNITED KINGDOM

Tamlyn UK profiles data sheets 10mm trims Cedral etc.

- ◆ Material - Aluminium alloy - typically 1050A series, but could be 3000, or 5000 depending on project specification.
- ◆ Dimensions - Individual product dimensions are on the attached drawings. Trims are typically 3000mm long.
- ◆ Temper - H14 (half hard)
- ◆ Gauge - 1mm for most profiles, but could be thicker depending on girth or usage. Individual drawings (attached) have the gauge details.
- ◆ Coating - Usually powder coated to Qualicoat standards which is a minimum thickness of 40-60 mu. Higher specification coatings for C5-M and C5-I are also available. Powder coating offers superior durability, colour fastness and scratch resistance over precoated Polyester. There are also no sharp edges or stress cracking on tight radii.
- ◆ Fire performance - Powder coated Aluminium gives a fire performance of class A2. Mill finish aluminium is class A1.
- ◆ Warranty - Our standard coating warranty is up to 30 years (project specific). 40 years is also available, subject to location , but utilises a higher specification powder coat. Aluminium in its natural state has a lifespan well in excess of 100 years when used as an external construction product. For trim products our standard warranty is 15 years.
- ◆ Recycled content - typically 60% minimum recycled aluminium is used in the product.
- ◆ Packaging plastics have a recycled content of 30%.



XT CLEC

C-LAP External corner (1mm)

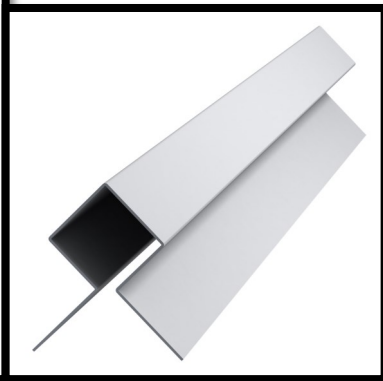
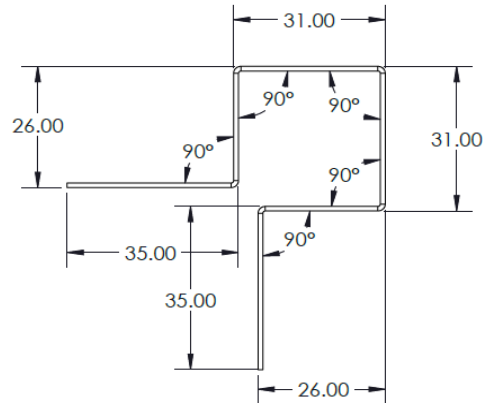

XT CLIC

C-LAP Internal corner (1mm)

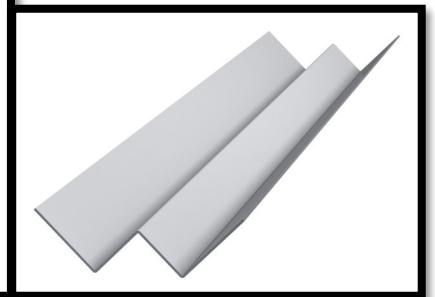
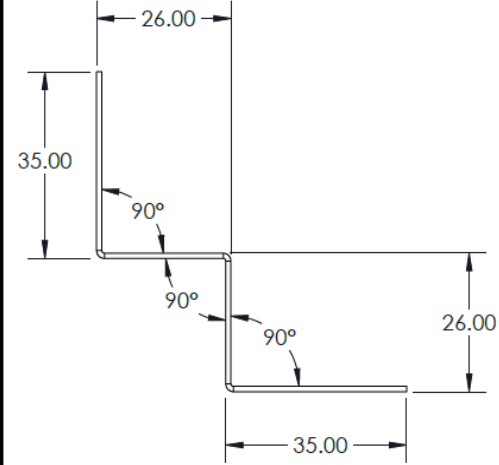

XT CLAEC

C-LAP Asym External corner (1mm)

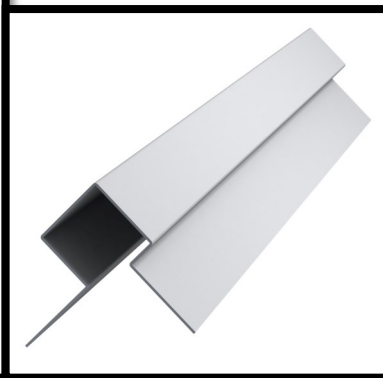
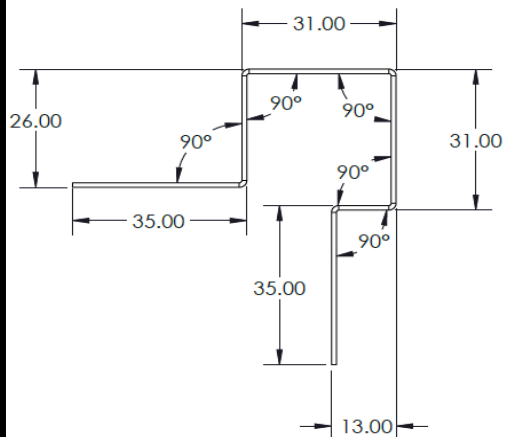

XT CLEP
C-LAP End profile (1mm)

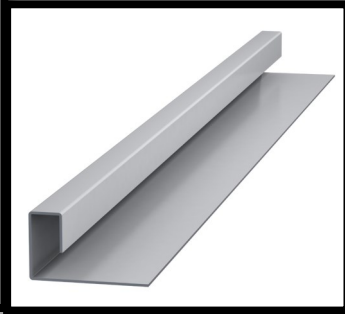
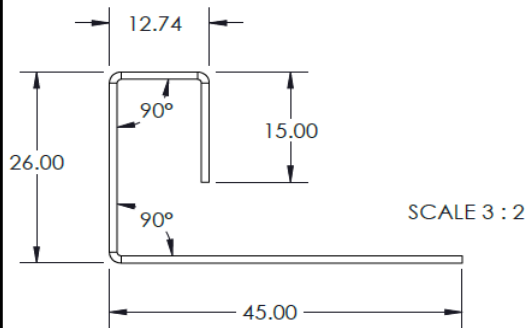

XT CLSP
C-LAP starter profile (1mm)

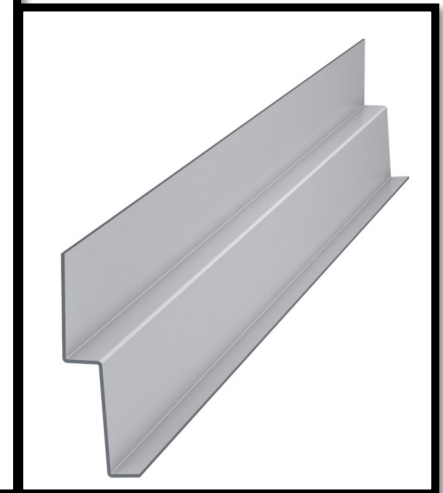
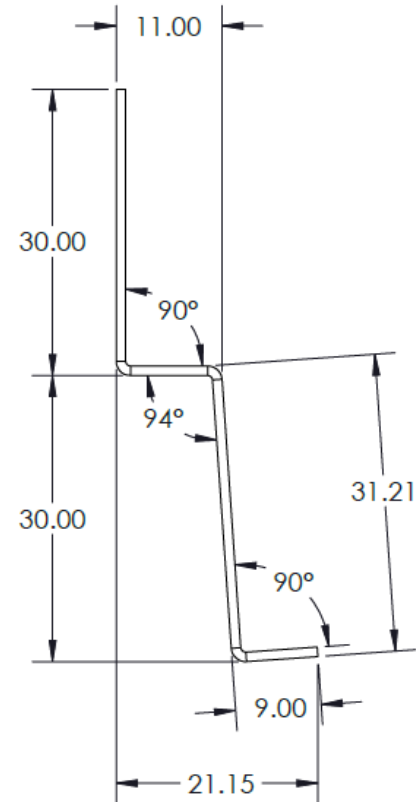

XT CCCP
C-CLK Connection profile (1mm)

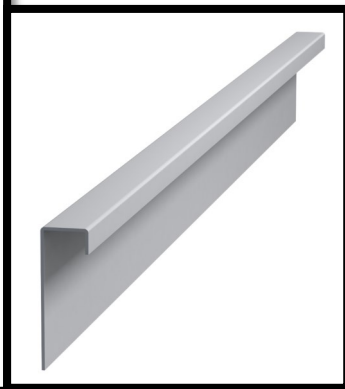
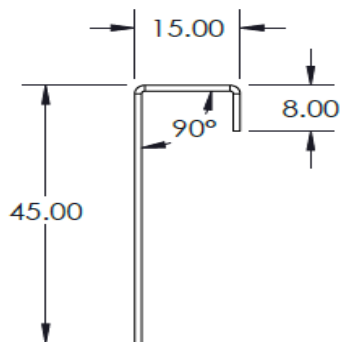

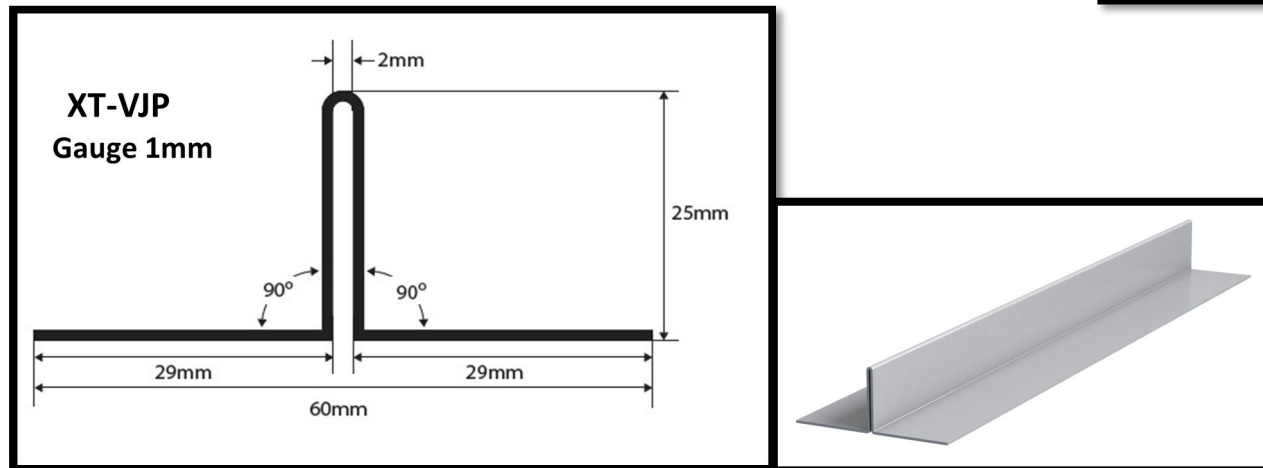
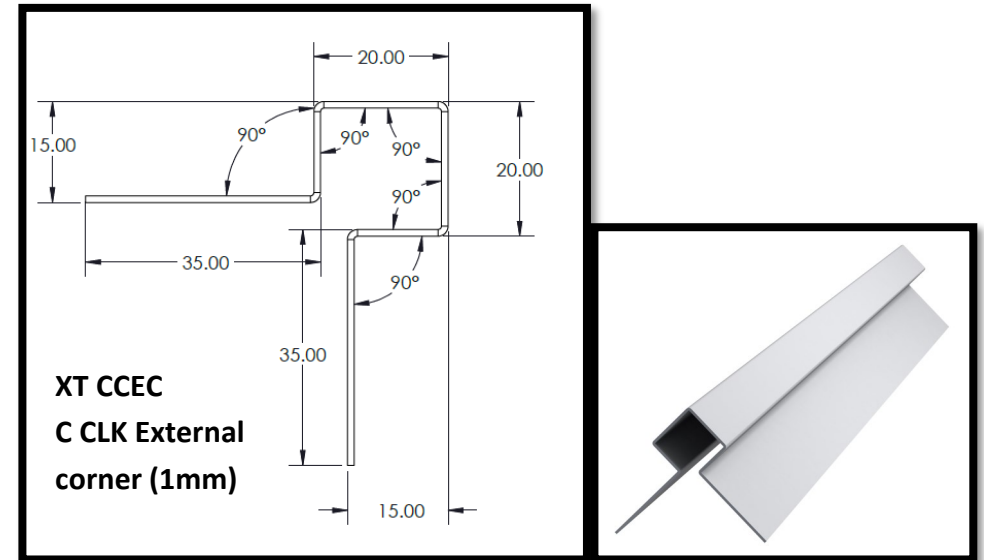
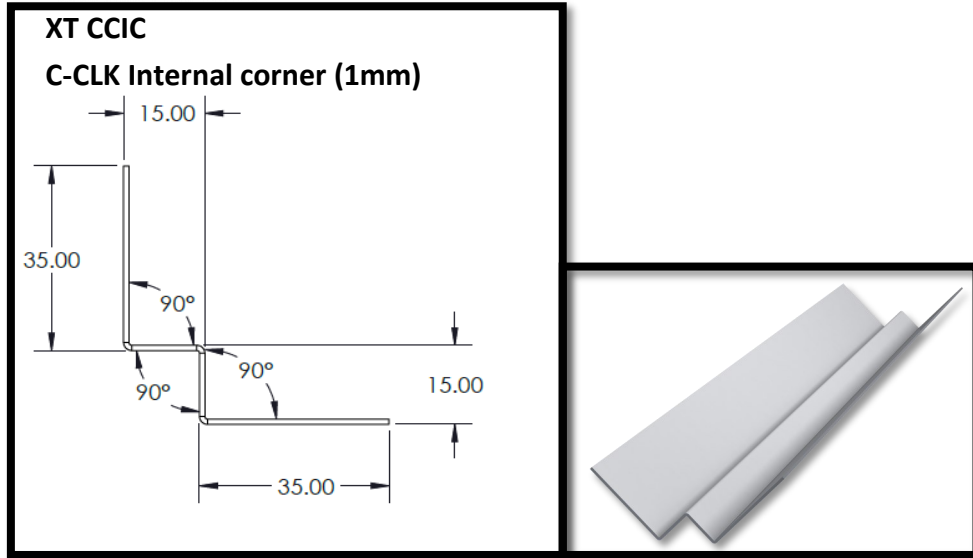

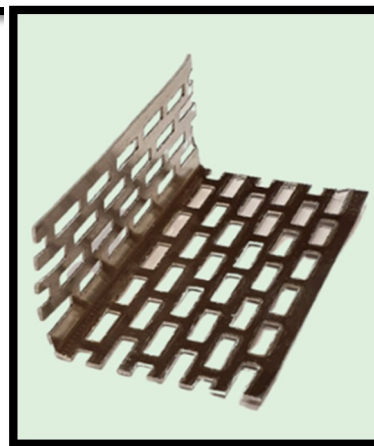
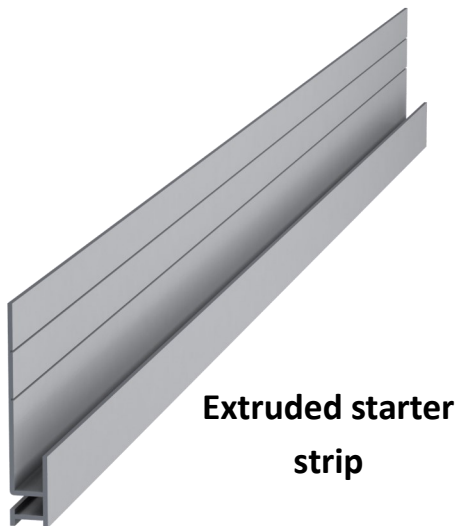
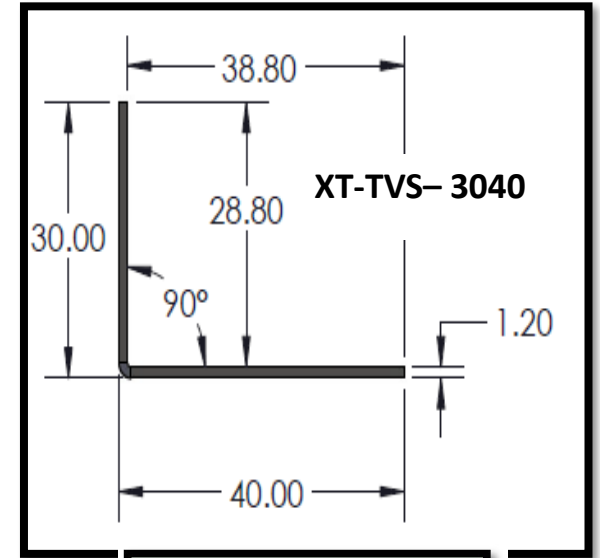
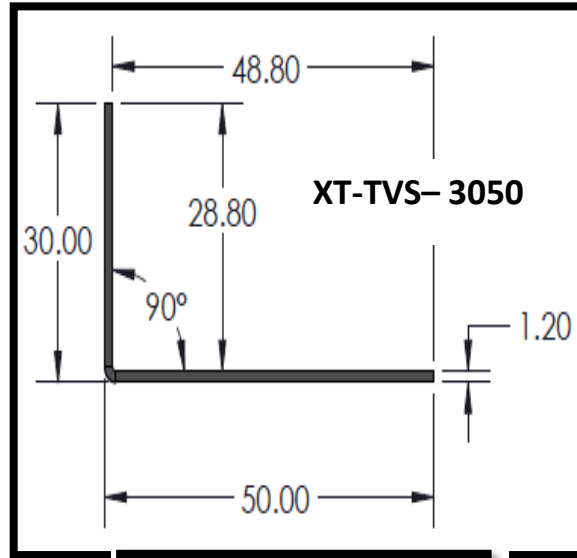
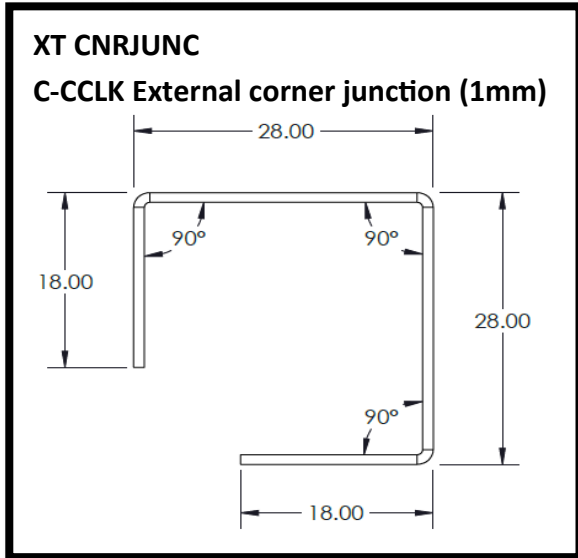

TVS3050

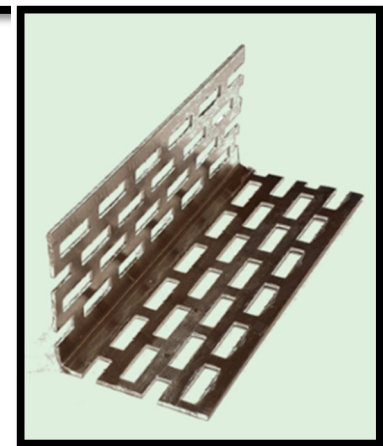

TVS3040



CLEANING AND MAINTENANCE

As with any organic coating, in order to retain the aesthetic qualities and the expected long term durability of the powder coating, it is important that the coating is cleaned regularly.

The frequency of cleaning depends upon the environment in which the coating is in service and in line with the terms outlined in the guarantee.

It should be noted that one of the conditions of the guarantee is that the coating is cleaned at the specific frequency and that the building owner retains proof of cleaning. Cleaning of the powder coating is an important part of the routine maintenance of the building. It is for this reason that we advise that only companies who specialise in this type of work are used for large cleaning operations.

Cleaning of Small areas

The powder coating can be cleaned by using a solution of mild detergent in warm water. All surfaces should be cleaned using a soft cloth, sponge or a natural bristle brush. Abrasive materials should be avoided, as they will damage the coating. If the coating has become heavily soiled it may be difficult to remove this soiling using only a mild detergent.

In order to overcome this problem, any mild, non-abrasive household cleaner may be used (after applying to a small test area first). Cleaners containing Esters, Ketones or chlorinated hydrocarbons must not be used.

Should oil or grease deposits exist, strong solvents must not be used to remove them. White spirit has been tested and approved for this purpose.

Whilst tests show that products of this type may be used successfully in the removal of heavy surface deposits, particular care must be exercised in their use to avoid any scuffing of the powder coating.

It is recommended that in all cases, such products are reserved for heavy soiling only and should be tested on small areas of the soiled powder coating first to assess their efficiency.

After application, all detergents and cleaners must be thoroughly rinsed away with clean water.





UK Head Office

**Unit 1A, Generation House,
Crab Apple way, Vale Business
Park, Evesham,
Worcestershire, WR11 1GP**

Tel: 01386 570898

sales@tamlyn.uk

www.tamlynbuildingproducts.co.uk



TAMLYN®
UNITED KINGDOM